

# Chaney Adapters

Congratulations! You have purchased the finest quality precision fluid management device available today. We combine top quality materials with skilled workmanship, ensuring the highest possible performance level of every precision fluid device we manufacture. With proper care and handling, Hamilton Chaney Adapters (p/ns 14700 and 14725) will provide unsurpassed performance in precision liquid handling year after year.

**Syringes and needles manufactured by Hamilton Company are intended for scientific research and laboratory use only and are not intended for human *in vivo* use.**

The Hamilton Chaney Adapter is a device that assures repetitive and identical syringe plunger location. It eliminates subjective errors when setting a syringe plunger at a specific volume.

Hamilton Company manufactures several types of Chaney Adapters for various applications and syringe models. Each Chaney Adapter is available as an optional accessory for syringes purchased separately.

When you select a syringe for installation into a Chaney Adapter, Hamilton recommends that the maximum pre-set volume does not exceed 80% of the total volume of the syringe. By using 80% or less of the syringe's scale length, the overall length of the syringe (with the Chaney Adapter attached) is less cumbersome. Furthermore, the overfill-stop-inject sequence is quicker.

**Note: While a Chaney Adapter insures repetitive plunger placement, other conditions may affect sample volume delivery such as sample viscosity, syringe and needle size, temperature, rate of injection, syringe filling techniques, and the condition of the syringe. Also, the Chaney Adapter will not prevent plunger bending that may result from an improperly maintained syringe.**

## Installation

Install Chaney Adapter (p/n 14700) on any Hamilton Series 701 Microliter™ syringe, or any Hamilton Series 1701 Gastight® syringe.

Install Chaney Adapter (p/n 14725) on any Hamilton Series 702 through 1750 Microliter™ syringe, any Series 7000 Modified Microliter™ syringe, or any Hamilton Series 1702 through 1750 Gastight® syringe.

Follow these steps to install the Chaney Adapter. Refer to Figure 1 for part numbers (in parentheses) in the text.

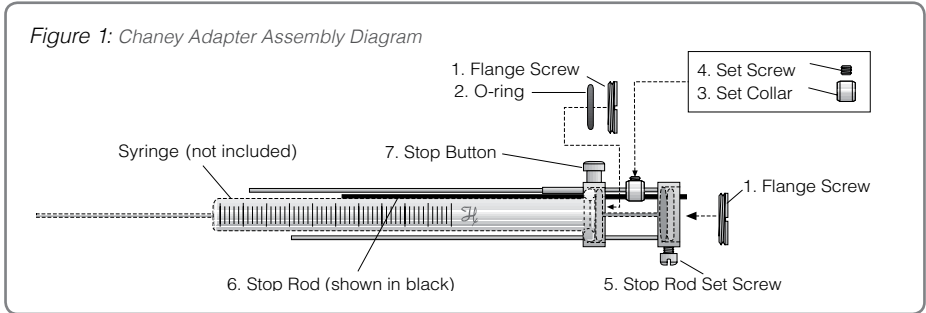

**Note: Do not handle a Microliter™ plunger shaft because oil and dirt from your fingers may cause the plunger to freeze in the syringe. To prevent this, wipe the plunger with a lint-free tissue.**

**Note: Gastight® plungers must be wet before installing them into syringe barrels.**

**Note: When installing Chaney Adapters on several Microliter™ syringes at one time, do not interchange plungers. Plungers are not interchangeable on Microliter™ syringes.**

1. With the plunger removed, place the syringe on a clean, dust-free surface.
2. Separate the two halves of the Chaney Adapter (Figure 2).

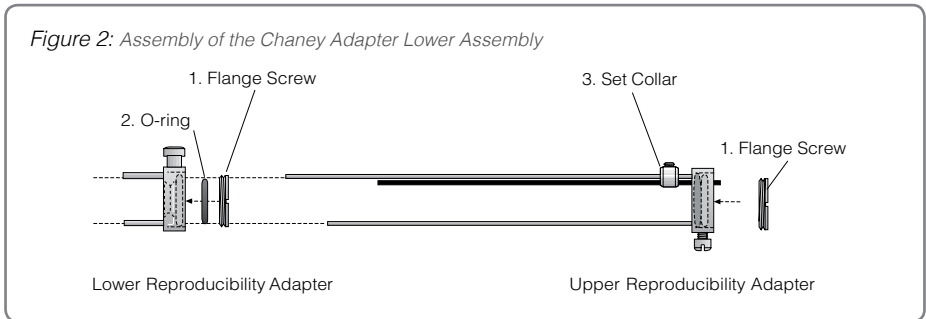

3. Using a screwdriver, loosen the lower Chaney Adapter flange screw (turns counterclockwise). Remove the flange screw (1) and the O-ring (2).
4. Insert the syringe barrel through the hole in the lower Chaney Adapter.
5. Place the O-ring on the top of the syringe flange and replace the flange screw (Figure 3). Tighten the flange screw firmly while holding the syringe so that both the syringe scale and the stop button (7) face you.

**Note: Use caution when tightening the flange screw on 7000 Series Modified Microliter™ syringes. These syringes have an inner sleeve in the glass barrel that extends beyond the glass flange. Ensure that the screwdriver blade does not damage the inner sleeve when tightening.**

- Loosen and remove the flange screw (1) from the upper Chaney Adapter. Insert the plunger into the upper Chaney Adapter.

*Figure 3: Assembly of the Chaney Adapter Upper Assembly*

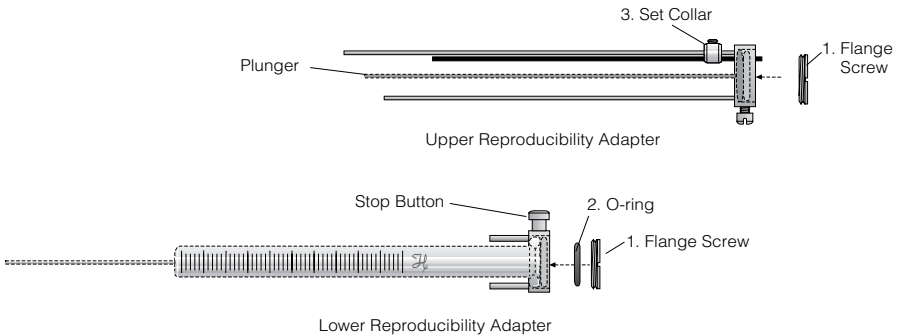

- Replace and tighten the flange screw, holding the plunger firmly in place.
- Slide the set collar (3) to the top of the longest rod on the upper Chaney Adapter and tighten it with the Allen wrench.
- Join the upper and lower halves of the Chaney Adapter, being careful to not bend the plunger. The upper and lower halves will be square with one another when installed correctly.
- Bring the upper and lower halves together gently until the plunger reaches the zero mark (Figure 4).

*Figure 4: Final Assembly of Chaney Adapter*

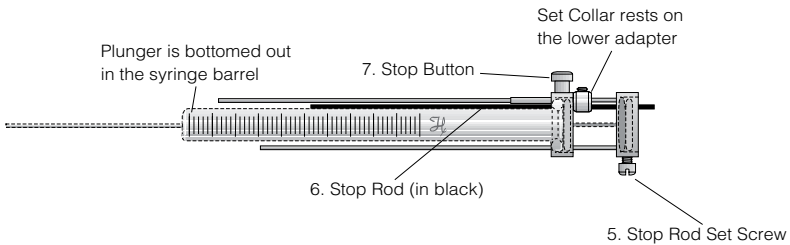

- Place the set collar against the lower Chaney Adapter, and tighten the set screw. This will prevent the plunger from damaging the bottom of the barrel upon rapid injection.

### Presetting the Desired Volume

To set the desired volume, follow these steps:

- Set the plunger at the desired delivery volume.
- Loosen the stop rod set screw (5) and slide the stop rod (6) out so it just clears the lower Chaney Adapter.
- While maintaining the desired plunger setting, push in and hold the stop button (7). Push in the stop rod until it bottoms against the stop button. Tighten the stop rod set screw, and release the stop button.

**Note: You have the option of installing the set collar to prevent the plunger from disengaging from the syringe during normal operation. If you choose this option, place the set collar on the very end of the stop rod after assembling the two halves of the Chaney Adapter, and tighten the set collar set screw.**

## Operating the Reproducibility Adapter

To operate the preset Chaney Adapter follow these steps:

1. Hold the lower Adapter. While the needle is in the sample, pump the plunger several times. This will wet the plunger.
2. Overfill the syringe.
3. Press the spring-loaded stop button; push the plunger forward until the stop rod stops against the stop button; release the stop button.
4. Dispense the syringe contents.

## Replacement Parts & Supplies

Description	Part Number
Chaney Adapter (1701 Series Gastight®, 701 Series Microliter™ Syringes)	14700
Chaney Adapter (for 1702–1750 Series Gastight®, 750 Series Microliter™, or 7000 Series Modified Microliter™ Syringes)	14725
Flange Screw	14704
O-ring	16102
Set Collar	16444
Set Screw	16435
Allen Wrench	2389-01

## WARRANTY STATEMENT

Hamilton Company unconditionally guarantees its products to be free of defects in materials and workmanship. Any product which fails due to such a defect will be repaired or replaced at our discretion without cost, provided the device is returned on a Return Materials Authorization (RMA). It is the responsibility of the purchaser to determine the suitability of application and material compatibility of the products based on the published specifications of the products.

## RETURN OF GOODS

Hamilton Company's return and repair policy is written to protect its employees from potentially hazardous materials (e.g. serum, radioactive materials, carcinogenic chemicals, etc.) or any substance that may cause them partial or permanent disability during the inspection or repair process. In returning a product, the customer acknowledges that the product is free from any hazardous materials. Furthermore, the customer assumes responsibility should the returned product be determined to be hazardous.

Gastight is a registered trademark of the Hamilton Company.  
© 2017 Hamilton Company. All rights reserved.  
All trademarks are owned and/or registered by Hamilton Company in the U.S. and/or other countries.  
Lit. No. 69192 Rev. G – 1/2017

**HAMILTON** 

Distributed By



Greyhound Chromatography and Allied Chemicals  
6 Kelvin Park  
Birkenhead  
Merseyside, CH41 1LT

Tel: 0151 649 4000 Fax: 0151 649 4001  
Email: [info@greyhoundchrom.com](mailto:info@greyhoundchrom.com)  
Web: <https://www.greyhoundchrom.com>